

# NEOSTONE 2.5

## FREESTANDING STOVE FOR MEDIUM TO LARGE SPACES

Heat Output Cord Wood

# 85,000 BTU

32,600 BTU EPA Test Fuel

EFFICIENCY (LHV)	80.3%
EFFICIENCY (B415)	74%
EMISSIONS	2.9 GM/HR.
LOG SIZE (MAX)	18 IN.
FIREBOX SIZE	2.5 CU.FT.
GLASS SIZE	184 SQ.IN.
WEIGHT	809 LB.

Powerful performance and natural beauty, introducing the NEOSTONE 2.5 for medium to large spaces. Like its smaller cousin the NEOSTONE 1.6, we took our highly efficient NEO 2.5 engine and elegantly wrapped it in soapstone. The natural properties of each unique large-scale piece of mined soapstone retains heat while the stove is in use and slowly releases the heat back into the room, even after the stove is out.

For reference only. Installations should be based on installation manuals. Specifications subject to change.

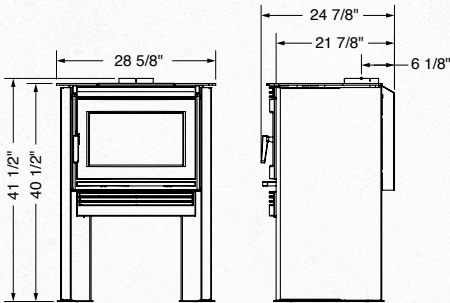

### STANDARD FEATURES

- EPA Certified
- Reliable, durable non-catalytic technology
- 35mm thick mined Soapstone top and side panels
- Air wash system for super clean ceramic glass
- Easy to use ash disposal system
- High-tech multi-port combustion air injection system
- Inside and outside combustion air capable
- Floating firebox for extended stove life
- 304 Stainless Steel Baffle, insulation cover, rails and flame shield
- Boost air for easy lighting
- Extended Burn Technology (EBT2)
- Integrated heat exchanger
- Single-Lever Air Control
- Removable Cast Iron Trivet

- East-West loading
- Leveling Legs
- Mobile Home Approved

### PERFORMANCE OPTIONS

- 140 cfm temperature actuated variable speed blower

### SOAPSTONE

Mined soapstone characteristics will vary from stove to stove. Being formed in nature, the appearance of the grain and colour cannot be controlled, making each stove unique.

