

MIRAGE 30

FREESTANDING GAS STOVE FOR MEDIUM TO LARGE SPACES

Natural Gas

30,000 BTU

26,000 BTU Liquid Propane

P.4.1-15 EFFICIENCY NG	68.7%
P.4.1-15 EFFICIENCY LP	69.9%
AFUE NG	72.8%
AFUE LP	74.1%
GLASS SIZE	275 SQ.IN.

The Mirage 30 represents the leading edge of freestanding design for larger spaces. Beautifully clad in lustrous porcelain enamel, inside each Mirage is a powerful engine. Large formed aluminum-finned heat exchangers result in high performance heating efficiency while highly reflective titanium porcelain baffles, and insulated interior firebox panels, maximize temperature convection. And because hot air rises, it makes sense to force hot air from the bottom of the stove rather than the top like conventional systems do. Thanks to a unique floor-level heat output system, you can maintain an ideal temperature from floor to ceiling. One-touch programmable remote controls simplify operation; heat output and flame height are variable, allowing complete control over heating, comfort, and appearance.

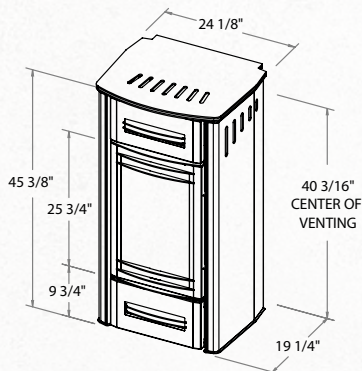

For reference only. Installations should be based on installation manuals. Specifications subject to change.



AVAILABLE BURNERS



FEATURES

- Direct Vent Technology
- SIT Pro Flame 2 valve
- Full Flames
- Ground Level Heat Output
- High-Efficiency Heat Exchanger with Aluminum Fins
- Black Porcelain interior panels
- 110 CFM Blower
- Integrated Micro-Mesh Safety Screen
- Standard Remote Control
- Minimal Vertical Venting
- Leveling Legs
- Mobile home approved

DESIGN OPTIONS

- Design-A-Fire
- Porcelain Steel Cladding in 4 colour options
- Burner: Logset or Glass

